

Bailey

700 Series

Safety Relief Valves

The Bailey 700 Series of Safety Relief Valves offers a broad spectrum of protection against over-pressure for vital services such as steam, air, gases, water and process fluids. The 700 Series Safety Relief Valves offer full protection, with maximum discharge capacity provided by features such as full lift, top guided construction and unobstructed seat bore. No matter what the application, all valves are designed for leak-free operation thanks to the choice of various seating materials.

Global legislation, covering all pressure equipment and systems, requires regular inspection of plant, pipework and safety provisions. Bailey Safety Relief Valves have demonstrated proven reliability over many years and require minimal maintenance.

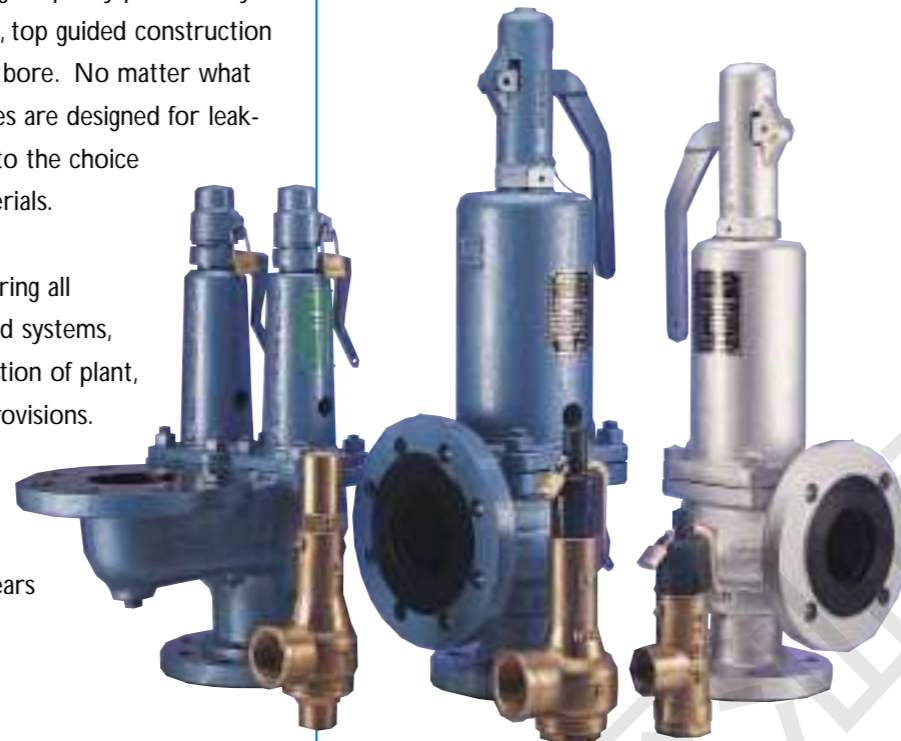

Bailey's design service can help to specify the most appropriate size and type of valve for any specific application, with the ability to include special modifications where necessary.

THE LOGICAL CHOICE

Experience and focus on customer service make Bailey the logical choice of supplier for safety valves to protect pipework, boilers and vessels - across a wide range of applications. A policy of continuous improvement ensures that Bailey valves will always meet current legislative requirements and of course provide exceptional reliability and performance.

By choosing Bailey Safety Relief Valves, you are selecting availability, quality, professional advice and proven performance - all delivered through an extensive worldwide network of distributors. Should a valve change-out be required at short notice, ex-stock availability of most standard valves ensures minimal plant downtime and maximum protection.

Bailey

700 Series

The complete solution with global support

APPLICATIONS TABLE - 700 SERIES

Application	Medium	700 Series Safety Relief Valve
Vented boilers Un-vented boilers	Hot Water	706 716 746/766
Boiler, pipeline and vessel protection	Steam	706/716 746 756/766
Compressor pipeline and receiver protection	Air	706 716 746
Pipeline and vessel protection	Cold Water	706 716 746
Process pipeline and vessel protection	Process/Corrosive Liquids	716 Stainless steel 746 Stainless steel
Clean steam and hygienic environments	Steam and Gases	716 Stainless steel 746 Stainless steel
Pipework, tank and equipment protection	Cryogenic Gases	776
Pipework, tank and equipment protection	Cold & Fine Gases	716 776

The selection of 700 Series figure number for each application depends on:
Pressure - capacity - material - temperature - fluid - connection required.

CONTENTS

	Page No.
Definitions	2 - 3
Valve Information and Numbering Systems	4 - 10
Installation	11
Dimensions	12 - 13
Air Capacity Table	14 - 15
Steam Capacity Table	16 - 17
Water Capacity Table	18 - 19
Hot Water Capacity Table	20 - 21
706/716 Spring Selection	22 - 23
Technical Specification	24

DEFINITIONS

Safety Valve

A valve which automatically discharges gases and vapours so as to prevent a predetermined safe pressure being exceeded. It is characterised by a rapid full opening action and is used for steam, gases or vapour service.

Relief Valve

A valve which automatically discharges fluid, usually liquid, when a predetermined upstream pressure is exceeded. The term is commonly used for pressure relieving valves in which the lift is proportional to the increase in pressure above the set pressure.

Safety Relief Valve

A valve which will automatically discharge gases, vapours or liquids, to prevent a predetermined safe pressure being exceeded. It is characterised by a rapid opening action.

Accumulation

The pressure increase over a maximum safe working pressure of the vessel or system when the safety relief valve is discharging at its rated capacity is called accumulation. The term refers to the vessel or system to be protected and not to the valve. Accumulation is the same as over-pressure when the valve is set at the design pressure of the vessel.

PRESSURE TERM RELATIONSHIP

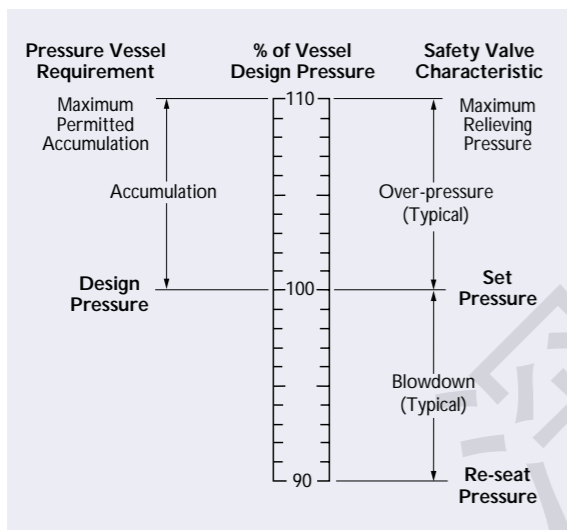

Note: System operating pressure must always be less than re-seat pressure.

Set Pressure

The pressure measured at the valve inlet at which a safety relief valve should commence to lift under service conditions.

Overpressure

The pressure increase above set pressure at the valve inlet at which the discharge capacity is attained. Usually expressed as a percentage of set pressure.

Re-Seat Pressure

The pressure measured at the valve inlet at which the safety relief valve closes.

Blow-Down

The difference between the set pressure and the re-seating pressure expressed as a percentage of the set pressure or as a pressure difference.

Simmer

The pressure zone between the valve set pressure and the popping pressure. In this pressure zone the valve is only slightly open and therefore discharging a small percentage of its rated capacity.

DEFINITIONS

Popping Pressure

The pressure at which the valve disc rapidly moves from a slightly open (simmer) position to a practically full open position.

Superimposed Back Pressure

Pressure higher than atmosphere in the safety valve outlet. This may result from discharge into the common disposal system of other safety valves or devices, or as a result of a specific design requirement. Back pressure can be either constant or variable depending on the operating conditions.

Built Up Back Pressure

The pressure existing at the outlet of a safety valve caused by flow through the valve into the disposal system.

Differential Set Pressure

This is the difference between the set pressure and the constant superimposed back pressure. It is applicable only when a conventional type safety relief valve is used to discharge against constant superimposed back pressure. (It is the pressure at which the safety valve is set at on the test bench without back pressure.)

Cold Differential Set Pressure

The pressure at which a safety relief valve, intended for high temperature service, is set on a test rig using a test fluid at ambient temperature. The cold differential test pressure will be higher than the set pressure, in order to compensate for the effect of elevated temperature on the valve.

Valve Lift

The actual travel of the valve disc away from the seat when the valve is relieving.

Discharge Capacity

Actual rate of discharge of service media, which can be expressed in mass flow or volumetric terms.

Equivalent Capacity

Calculated mass or volumetric flow rate of the valve of a given test fluid. The fluids commonly used for test purposes are steam, air and water.

BS 6759 TOLERANCES FOR 700 SERIES SAFETY RELIEF VALVES

PART	% Overpressure	% Blowdown	Medium
Part 1	5% on 716/746/756/766 10% on 706	*0.3 Barg or 5% on 756 or 10% on 766 *0.3 Barg or 15% on 706/716/746	Steam and Hot Water 100°C or Above
Part 1	5% on 716/746/756/766R 10% on 706	*0.6 Barg or 20% on 706/716/746/756/766R	Hot Water Below 100°C
Part 2	10% 706/716/746	*0.3 Barg or 10% on 706/716/746	Compressed Air and Inert Gases
Part 3	10% on 706/716/746	15% on 706/716/746	Gases
Part 3	10% 706/716/746	*0.6 Barg or 20% on 706/716/746	Liquids
AD MERKBLATT			
A2 (TUV)	10% on 776	10% on 776	Air and Gases
A2 (TUV)	5% on 746	10% on 746	Steam, Air and Gases

*Whichever is the greater.

706

DESIGN

The 706 Safety Relief Valve is designed to take full advantage of its high lift capability by incorporating top guiding, which provides an unobstructed seat bore.

Positive reseating is achieved by a freely pivoting EPDM disc in the standard valve, for potable water duties up to 95°C. The Aflas trim is suitable for air, gas, vapour, or liquid duties up to 200°C while providing greater resistance to chemical attack. The metal disc option is primarily designed for use on high temperature duties above 200°C. Fitted with a test lever for inline safety checking, or alternatively with a sealed dome for service conditions requiring a pressure tight seal on the discharge side, eg. liquid service with enclosed discharge.

The body material is cast bronze ranging from DN15 to DN50 in size.

FEATURES AND BENEFITS

- Certified to BS6759 parts 1, 2 and 3 by SAFED/AOTC.
- High Lift, high coefficient flow capability.
- Top un-wetted guiding giving unobstructed seat bore.
- Each valve individually tested and set.
- Water Research Council (WRC) listed (certificate no. 9404007).
- Positive re-seating with either resilient or metal trims.
- Low stress springs to BS6759.

CE MARKING

This range of Safety Relief Valves has been certified to the requirements of the PED. Set pressures below 0.5 Barg do not require certification, hence cannot be CE marked.

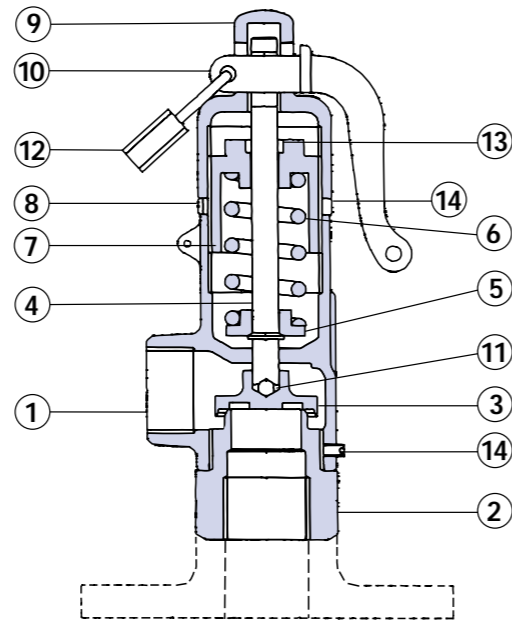

ITEM	PART	MATERIAL
1	Body	Bronze
2	Seat	Bronze
3*	Disc	Various
4	Spindle	Brass
5	Spring Cap	Brass
6*	Spring	Chrome vanadium
7	Adjusting Screw	Bronze
8	Locking Ring	Bronze
9†	Dome	Nylon
10	Lever	Bronze
11*	Ball	Stainless Steel
12	Padlock	Brass
13	Bush	PTFE
14	Pinning Screw	Steel

Note:
 * Recommended spares.
 † Synthetic dome should not be adjacent to external heat sources.
 Flange options: BS10 Table E and F, BS4504 PN16/25 and ANSI 150.
 Certified Drawings are available with material parts list.

FIGURE NUMBERING SYSTEM

706

TRIM	CONNECTIONS	CAP
E EPDM	S Screwed in and out (Inlet available Male or Female)	D Pressure tight dome
V Viton		
M Metal		
	F Flanged in screwed out	L Open lever

716

DESIGN

The 716 Safety Relief Valve combines a top guided, unobstructed seat bore with full lift capability to provide maximum discharge capability.

Positive reseating is achieved with freely pivoting EPDM discs for gas, hot water and other liquid duties up to 150°C. Optional Aflas soft seats increase the range to 200°C. Precision lapped stainless steel trim gives positive re-seating for steam duty up to 230°C. Fitted with a test lever for inline safety checking, or alternatively with a sealed dome for service conditions requiring a pressure tight seal on the discharge side, eg. liquid service.

The body material is available in cast bronze, iron and stainless steel, ranging from DN15 to DN50 in size.

FEATURES AND BENEFITS

- Certified to BS6759 parts 1, 2 and 3 by SAFED/AOTC.
- Full lift discharge capacity.
- Top un-wetted guiding giving unobstructed seat bore.
- Each valve individually tested.
- Positive re-seating with either resilient or stainless steel trim.
- Discharge capacity at 5% overpressure on steam duty.
- Low stress springs to BS6759.

CE MARKING

This range of Safety Relief Valves has been certified to the requirements of the PED. Set pressures below 0.5 Barg do not require certification, hence cannot be CE marked.

FIGURE NUMBERING SYSTEM

716

CODE	TRIM	BODY	CONNECTIONS	CAP
AS	St. steel	St. steel	Screwed in and out	D Pressure tight dome
BS	Aflas		(Inlet available Male or Female)	
ES	EPDM	Bronze		L Open lever
VS	Aflas			
SS	St. steel			
AF	St. steel	St. steel	Flanged in screwed out	
BF	Aflas			
EF	EPDM	Bronze		
VF	Aflas			
SF	St. steel			
CF	EPDM	Cast iron	Flanged in and out	
DF	Aflas			
FF	St Steel			

Note:
 * Recommended spares.
 † Synthetic dome should not be adjacent to external heat sources.
 Flange options: BS10 Table E, F and H, BS4504, PN16/25 and ANSI 150.
 Certified Drawings are available with material parts list.

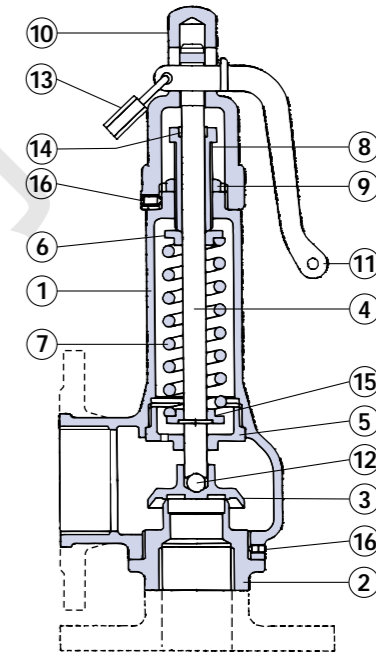

ITEM	PART	MATERIAL		
		Cast Iron	St.St.	Bronze
1	Body	Cast Iron	St.St.	Bronze
2	Seat	St.St.	St.St.	Bronze
3*	Disc	Various	Various	Various
4	Spindle	Brass	St.St.	Brass
5	Guide	Bronze	Nickel alloy	Bronze
6	Top Spring Cap	Brass	St.St.	Brass
7*	Spring	Chrome vanadium	St.St.	Chrome vanadium
8	Adjusting Screw	Brass	St.St.	Brass
9	Lock Nut	Brass	St.St.	Brass
10†	Dome	Nylon	St.St.	Nylon
11	Lever	Bronze	N/A	Brass
12*	Ball	St.St.	Monel	St.St.
13	Padlock	Brass	N/A	Brass
14	Bush	PTFE	PTFE	PTFE
15	Bottom Spring Cap	Brass	St.St.	Brass
16	Pinning Screw	Steel	St.St.	Brass

DESIGN

The 746 Safety Relief Valve incorporates a freely pivoting disc, which ensures correct alignment with the nozzle. The combination of top guiding, unobstructed seat bore and full lift capability ensures the highest possible discharge rate thus maximum plant protection. Body material is available in cast steel and stainless steel.

The 746 safety relief valve is available in both conventional and balanced bellows types, and features a special disc style for liquid application, ensuring trouble free performance.

The 'conventional' arrangement is suitable for applications where the built up pressure will not exceed 10%. The conventional valve can also be used in systems where the superimposed backpressure is at a constant level (up to 80%).

The 'balanced bellows' arrangement is for applications where several safety relief valves discharge into a common discharge manifold, or in any circumstances where a variable back pressure can occur, up to a maximum of 40%.

Valve size ranges from DN25 to DN100.

CE MARKING

This range of Safety Relief Valves has been certified to the requirements of the PED. Set pressures below 0.5 Barg do not require certification, hence cannot be CE marked.

FEATURES AND BENEFITS

- Certified to BS6759 parts 1, 2 and 3 by SAFED/AOTC.
- A.D.Merkblatt A2 (TUV Approval).
- ASME Code Section VIII. (National Board Approval).
- Stoomwezen rules A1301.
- Australian standard AS1271.
- Full lift maximum discharge capability.
- Each valve individually tested and set.
- Top un-wetted guiding giving unobstructed seat bore.
- Positive re-seating with either resilient or stainless steel trim.
- Comprehensive range of accessories.
- Precision lapped stainless steel trim.
- Discharge capacity at 5% overpressure on steam duty.
- Low stress springs to BS6759.

See Page 10 For Figure Numbering System.

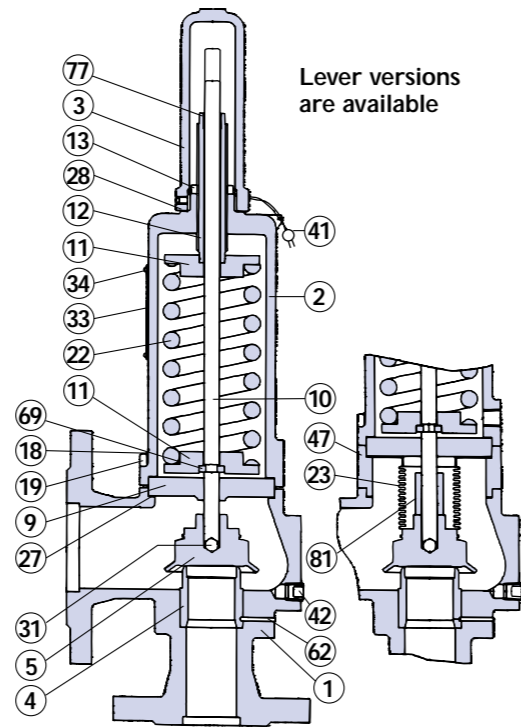

ITEM	PART	MATERIALS	
		Carbon Steel	St.St
1	Body	Carbon St	St.St
2	Bonnet	SG Iron	St.St
3	Cap	SG Iron	St.St
4	Seat	St.St	St.St
5*	Disc#	St.St	St.St
9	Guide Plate	St.St	St.St
10 (H)	Spindle	St.St	St.St
11	Spring Plate	St.St	St.St
12	Adjusting screw	St.St	St.St
13	Locknut	St.St	St.St
18 (H)	Body Stud	Carbon St	St.St
19	Body Nut	Carbon St	St.St
22 (H)	Spring**	C.V	St.St
23 (B)*	Bellows Unit	St.St	St.St
27*	Body/Bonnet Gasket	Garlock	Garlock
28*	Cap Gasket	Garlock	Garlock
31*	Ball	St.St	St.St
33	Nameplate	St.St	St.St
34	Nameplate Pin	Carbon St	St.St
41	Warranty Seal	Lead/wire	Lead/wire
42	Drain Plug	Carbon St	St.St
47(BH)	Spacing Piece	St.St	St.St
62	Seat Pin	St.St	St.St
69	Split Collar	St.St	St.St
77	Adjusting Screw Bush	PTFE	PTFE
81(B)	Lift Stop	St.St	St.St

Note:
 B - Denotes used on Bellows type valves.
 H - High Pressure type valves; and spacer and larger studs, spring and spindle.
 # Resilient trims are available.
 * Recommended spares.
 ** Other spring material options are available dependent on duty.
 Flange options: See page 10.
 Certified Drawings are available with material parts list.

DESIGN

The 756 Safety Valve combines a top piston guided valve and an unobstructed seat bore with a full lift capability, giving maximum discharge capacity. The design incorporates an adjustable blowdown ring and meets all the requirements of BS6759 Part 1.

A freely pivoting disc and precision lapped stainless steel trim gives positive reseating for steam duty. Fitted with test lever for inline testing. Ideally suited to applications on steam boilers and pipelines where blowdown tolerances are critical.

Body material is available in carbon steel, ranging from DN25 to DN80 in size.

CE MARKING

This range of Safety Relief Valves has been certified to the requirements of the PED. Set pressures below 0.5 Barg do not require certification, hence cannot be CE marked.

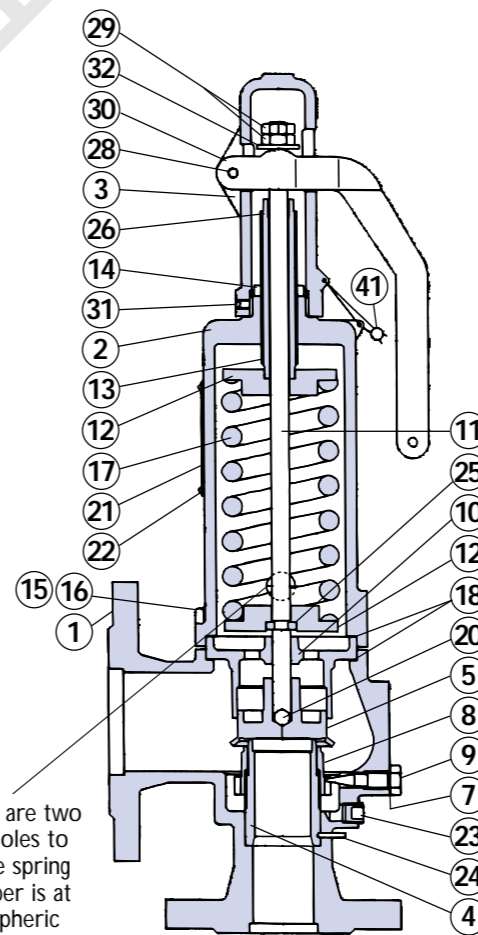

See Page 10 For Figure Numbering System.

FEATURES AND BENEFITS

- Certified to BS6759 Part 1 by SAFED/AOTC.
- Full Lift discharge capacity.
- Top un-wetted guiding giving unobstructed seat bore.
- Adjustable blowdown, to 5%.
- Each valve individually tested and set.
- All valves fitted with test lever and padlock.
- Precision lapped stainless steel trim.
- Low stress springs to BS6759.
- Discharge capacity at 5% overpressure.
- Piston design allows back pressure up to 50%.

ITEM	PART	MATERIAL
		Carbon Steel
1	Body	Carbon Steel
2	Bonnet	Cast Iron
3	Cap	Cast Iron
4	Seat	St.St.
5*	Disc	St.St.
7*	Set Screw Gasket	NAF
8	Blowdown Ring	St.St.
9	Setting Screw	Brass
10	Guide Plate	Bronze
11	Spindle	St.St.
12	Spring Plate	Brass
13	Adjusting Screw	Brass
14	Locknut	Brass
15	Body Stud	Carbon Steel
16	Body Nut	Carbon Steel
17*	Spring	Chrome Vanadium
18*	Body/Bonnet Gasket	NAF
20*	Ball	St.St.
21	Nameplate	St.St.
22	Nameplate Pin	Steel
23	Drain Plug	Steel
24	Seat Pin	St.St.
25*	Split Collar	St.St.
26	Adjusting Screw Bush	PTFE
28	Fulcrum Pin	St.St.
29	Spindle nut	Brass
30	Easing Lever	Carbon Steel
31	Grub Screw	St.St.
32	Spindle Washer	St.St.
41	Warranty Seal	Lead

Note:
 * Recommended spares.
 Flange options: See page 10.

Certified Drawings are available with material parts list.

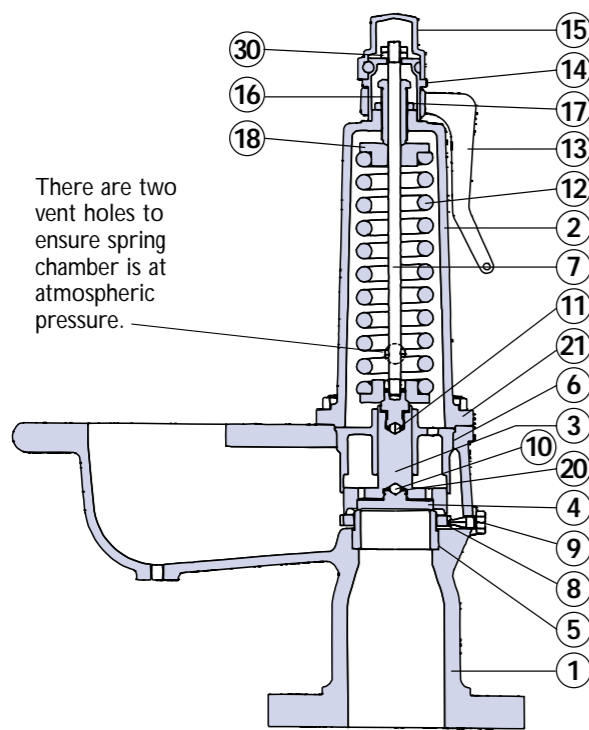

766

DESIGN

The 766 Safety Valve is a double spring high lift valve with high discharge capacity. The top guided piston design incorporates an adjustable blowdown ring and meets all the requirements of BS6759 Part 1.

A freely pivoting disc and precision lapped stainless steel trim gives positive re-seating for steam duty. Fitted with test lever for inline testing. Ideally suited to applications on steam boilers and pipelines where blowdown tolerances are critical.

Body material is available in cast iron and steel, ranging from DN40 to DN80 in size.

FEATURES AND BENEFITS

- Certified to BS6759 Part 1 by SAFED/AOTC.
- Top un-wetted guiding giving unobstructed seat bore.
- Adjustable blowdown, to 5%.
- Each valve individually tested and set.
- All valves fitted with test lever and padlock.
- Precision lapped stainless steel trim.
- Available with resilient seats for hot water applications. (766 Resilient)
- Low stress springs to BS6759.
- Piston design, metal seat valves only, allows back pressure up to 50%.

CE MARKING

This range of Safety Relief Valves has been certified to the requirements of the PED. Set pressures below 0.5 Barg do not require certification, hence cannot be CE marked.

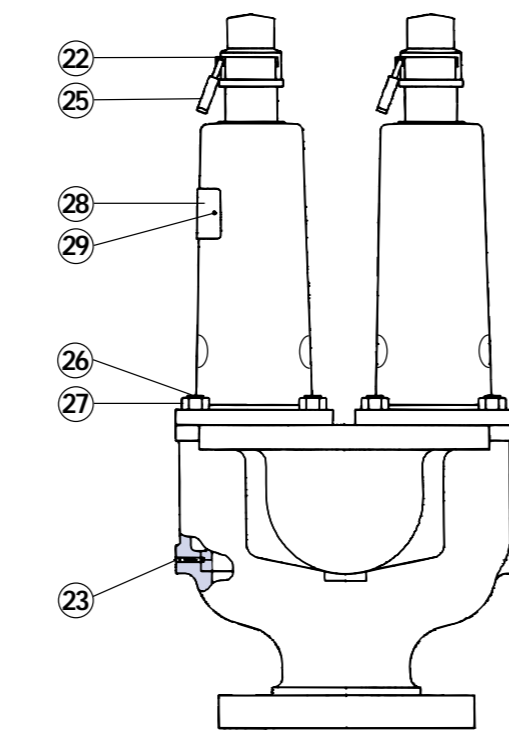

776

DESIGN

The 776 Safety Relief Valve is designed for cryogenic duty down to -196°C. The valve combines a full lift design and top guided construction with an unobstructed seat bore to provide maximum discharge capacity. Positive sealing is achieved through a freely pivoted disc with Kel F (PCTFE) soft seat technology.

Body material is available in bronze ranging from DN15 to DN50 in size.

FEATURES AND BENEFITS

- The valve is designed to conform with ISO4126, AD Merkblatt A2 and BS6759 Parts 2 and 3.
- The valve is certified by TUV, with flow rates and discharge coefficients certified in accordance with AD Merkblatt A2.
- The valve can be supplied certified to ASME VIII Div 1. Details available on request.
- Production assembly and tests are carried out in accordance with both BOC and Air Products specifications.
- Low stress springs to BS6759.

BOC specification: 1819660 and 399856.

Air Products specification: PSD A03, PSD J19, and EOM 1-1-71-21M.

CE MARKING

This range of Safety Relief Valves has been certified to the requirements of the PED. Set pressures below 0.5 Barg do not require certification, hence cannot be CE marked.

FIGURE NUMBERING SYSTEM

Fig.	Size	Trim	Connections
776/1	DN15 x 20		
776/2M	DN15 x 25		
776/2R	DN20 x 25		
776/2	DN20 x 25	Soft Seat	*Screwed
776/3	DN20 x 32	Kel F	BSP
776/2M1	DN25 x 25		
776/4	DN25 x 32	(PCTFE)	Male x Female
776/5	DN32 x 40		
776/6	DN40 x 50		
776/7	DN50 x 65		

* Other threaded options are also available.

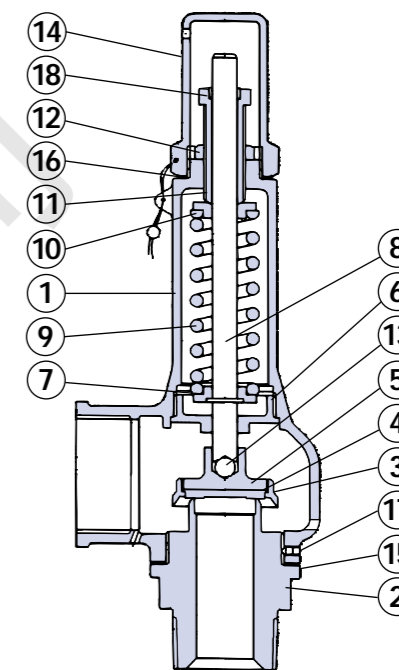

ITEM	PART	MATERIAL
1	Body**	Cast Iron or Carbon Steel
2	Cover	Cast Iron
3	Valve Disc Holder	Bronze
4*	Valve Disc	St.St.
5	Seat Ring	St.St.
6	Guide	Bronze
7	Spindle	St.St.
8	Blow Down Ring	St.St.
9	Setting Screw	St.St.
10*	Valve Disc Ball	St.St.
11*	Spindle Ball	St.St.
12*	Spring	Chrome Vanadium
13	Easing Lever	SG Iron
14	Dome	Bronze
15	Dome Cap	Grey Iron
16	Adjusting Screw	Brass
17	Locknut	Brass
18	Spring plate	Plated Steel
20*	Disc Retaining Clip	St.St.
21*	Body Gasket	Garlock
22	Locking Pin	Brass
23	Seat Securing Pin	St.St.
25	Padlock	Brass
26	Body Stud	Steel
27	Body Stud Nut	Steel
28	Nameplate	St.St.
29	Nameplate screw	Steel
30	Locknut	Steel

Note:

* Recommended spares.

** The only difference between both options is Item 1 the body.

Flange options: See page 10.

Certified Drawings are available with material parts list. See Page 10 For Figure Numbering System.

ITEM	PART	MATERIAL
1	Body	Bronze
2	Seat	Bronze
3	Valve Skirt	Brass
4*	Valve Disc	Kel F PTFE
5*	Valve Disc Holder	Monel K500
6	Guide	Bronze
7	Lower Spring Plate	Brass
8	Spindle	Brass
9*	Spring	St.St.
10	Upper Spring Plate	Brass
11	Adjusting Screw	Brass
12	Locknut	Brass
13*	Ball	Monel K500
14	Cap	Brass
15*	Body Gasket	Gylon PTFE
16*	Cap Gasket	Gylon PTFE
17	Grubscrew	St.St.
18	Bush	PTFE

Note:

* Recommended spares.

Certified Drawings are available with material parts list.

FIGURE NUMBERING SYSTEM 746/756/766

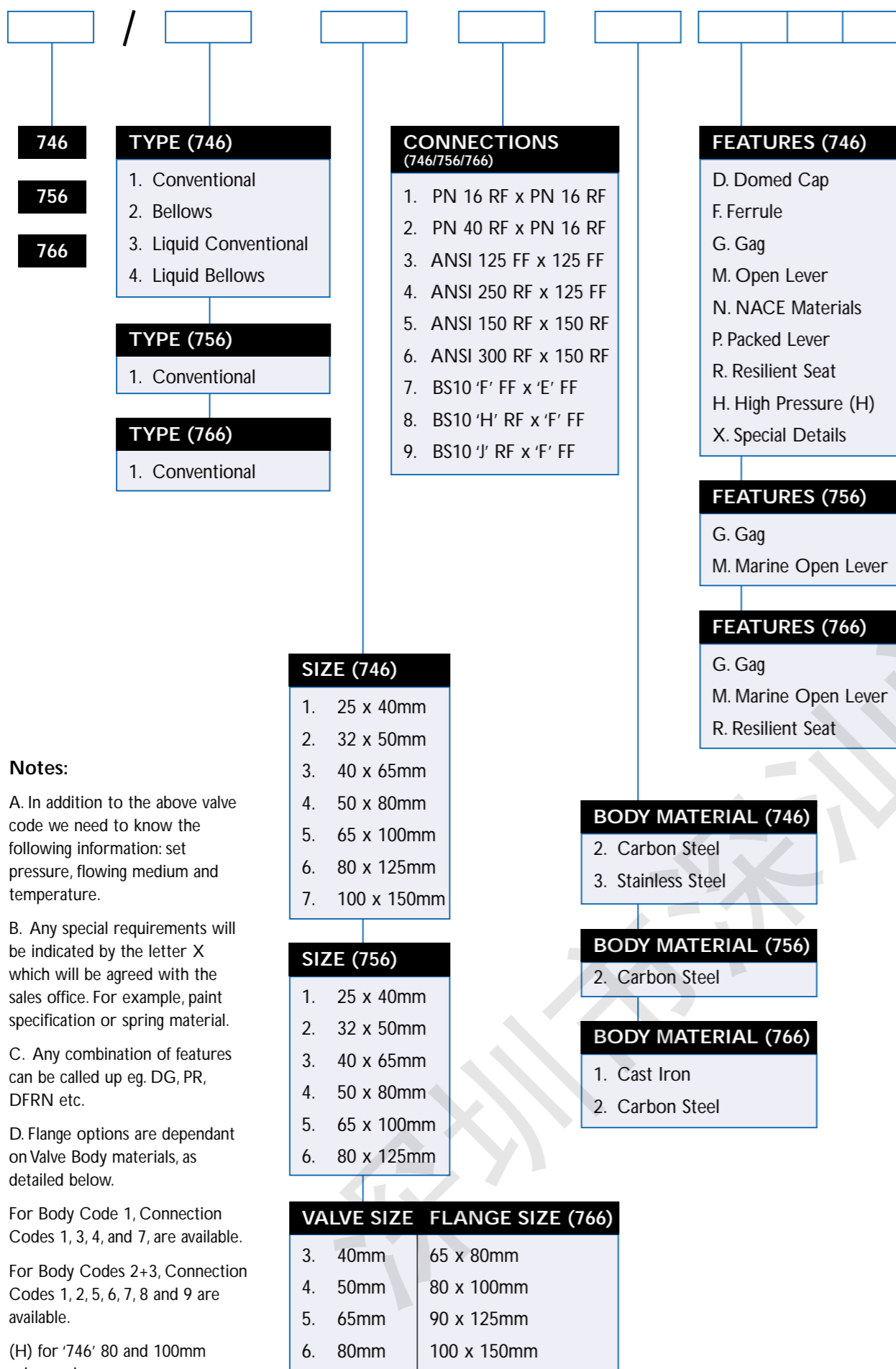

Notes:

A. In addition to the above valve code we need to know the following information: set pressure, flowing medium and temperature.

B. Any special requirements will be indicated by the letter X which will be agreed with the sales office. For example, paint specification or spring material.

C. Any combination of features can be called up eg. DG, PR, DFRN etc.

D. Flange options are dependant on Valve Body materials, as detailed below.

For Body Code 1, Connection Codes 1, 3, 4, and 7, are available.

For Body Codes 2+3, Connection Codes 1, 2, 5, 6, 7, 8 and 9 are available.

(H) for '746' 80 and 100mm valves only.

INSTALLATION

Safety Relief Valves should always be installed in an upright position with their spring chamber vertical. All packing materials should be removed from the valve connections prior to installation.

Pressure Vessels

When fitting a Safety Relief Valve onto pressure vessels, the inlet connection pipe should be as short as possible and the bore should be at least equivalent to the nominal bore size of the valve.

The pressure drop between the vessel and the valve should be no more than 3% at rated capacity.

A pressure-tight dome should be specified when:

- 1) A backpressure must be contained within the relieving system.
- 2) A head of liquid is built up within the valve body and consequently needs to be contained.
- 3) The relieving medium is toxic, corrosive or environmentally unfriendly.

Pipelines

When fitting a Safety Relief Valve into a pipeline, the inlet connecting pipe leading from the main pipeline to the Safety Relief Valve should be as short as possible, so that the inlet pressure drop is no more than 3% of rated capacity.

In addition, it is advised that the Safety Relief Valve is placed a sufficient distance downstream of the pressure source. This will protect the valve from the adverse effects of pressure pulsations.

Discharge Pipelines

These should be equal to or larger than the valve outlet, with adequate supports, minimum number of bends and overall length. Unless balanced bellows valves are installed, the maximum built up backpressure should not exceed 10% of the set pressure, although the 746, 756 and the 766 can handle higher back pressure if required. Steam service valves should be adequately drained. Alignment of the

discharge or drain should present no risk to persons or property. Protection from the collection of rainwater or condensation in the discharge pipe is advisable.

System Cleansing

It is essential that new installations are fully flushed and all debris removed prior to installing the valve as serious damage can be caused to valve seats, resulting in subsequent leakage.

Pressure Adjustment

Every valve is fitted with a suitable spring and tested before leaving the factory. Valves can be preset on request but to alter the set pressure, the adjusting screw, when viewed from the top, should be screwed downwards in a clockwise direction to increase the set pressure and upwards in an anti-clockwise direction to decrease it. Set pressure adjustment must be carried out by experienced and approved personnel. Any change in set pressure must be within the range of the existing spring, if it exceeds the range, a new spring will be required. The cap lead seal must be re-made after any adjustment to the set pressure.

Blow-down Adjustment (756 & 766 valves only)

The blow-down ring (part no. 8) is set before the valve leaves the factory and normally no further adjustment will be necessary. However, if the reseating pressure has to be altered in service, the blow-down ring should be screwed (downwards) clockwise to raise the re-seat pressure, lower the popping and simmer pressure; if the blowdown ring is screwed (upwards) anti-clockwise the re-set pressure will lower and the popping and simmer pressures will rise. When re-inserting the setting screw (part no. 9.) it should always be placed to engage a slot in the blow-down ring. The standard blow-down is 5% for 756 and 10% for 766 (minimum 0.3 barg). For recommended settings, please contact our technical sales office who will be pleased to help.

COLD DIFFERENTIAL TEST PRESSURE

When setting a valve intended for use at high temperature on a test rig using a test fluid at ambient temperatures, it is necessary to set the valve at a slightly higher pressure, so that it will open at the correct set pressure under operating conditions. The necessary allowance is shown in the following table.

Operating temperature – Centigrade	% Increase in set pressure at ambient temperature
Up to 121°C	None
122°C to 316°C	1
317°C to 427°C	2

Female x Female		Valve Type	Valve Size	Inlet (BSP)	Outlet (BSP)	A	'C' Dome	'C' Lever	D	Weight (kg)
	706	DN15	½"	½"	40	111	133	29	0.6	
		DN20	¾"	¾"	46	140	162	37	1.0	
		DN25	1"	1"	56	163	186	40	1.5	
		DN32	1¼"	1¼"	67	182	215	48	3.0	
		DN40	1½"	1½"	67	216	249	56	4.5	
		DN50	2"	2"	79	268	303	71	6.0	
716	DN15	½"	¾"	40	158	178	40	1.0		
	DN20	¾"	1¼"	44	209	232	55	1.6		
	DN25	1"	1½"	48	235	258	60	2.1		
	DN32	1¼"	2"	58	295	328	70	4.0		
	DN40	1½"	2½"	67	340	380	81	7.0		
	DN50	2"	3"	80	382	424	96	10.0		

Male x Female		Valve Type	Valve Size	Inlet *NB	Outlet (BSP)	A	'C' Dome	'C' Lever	D	Weight (kg)
	706	DN15	½"	½"	48	129	151	29	1.0	
		DN20	¾"	¾"	56	159	181	37	1.6	
		DN25	1"	1"	78	185	208	40	2.0	
		DN32	1¼"	1¼"	90	205	238	48	3.5	
		DN40	1½"	1½"	93	241	274	56	5.0	
		DN50	2"	2"	110	299	334	71	7.0	
716	DN15	½"	¾"	58	173	192.5	40	1.0		
	DN20	¾"	1¼"	63	229	252	55	1.6		
	DN25	1"	1½"	70	257	280	60	2.1		
	DN32	1¼"	2"	80	318.5	351	70	4.0		
	DN40	1½"	2½"	91	366.5	405.5	81	7.0		
	DN50	2"	3"	110	414.5	456.5	96	10.0		
776	DN15 /1	½"	¾"	52	173	—	40	1.0		
	DN15 /2M	½"	1"	52	173	—	40	1.0		
	DN20 /2R	¾"	1"	70	191	—	45	1.0		
	DN20 /2	¾"	1"	70	191	—	45	1.0		
	DN20 /3	¾"	1¼"	63	231	—	55	1.6		
	DN25 /2M1	1"	1"	70	191	—	45	1.0		
	DN25 /4	1"	1¼"	73	241	—	55	1.6		
	DN32 /5	1¼"	1½"	78	265	—	60	2.1		
	DN40 /6	1½"	2"	84	323	—	70	4.0		
	DN50 /7	2"	2½"	95	371	—	81	7.0		

Flanged x Female		Valve Type	Valve Size	Inlet *NB	Outlet (BSP)	A	B	'C' Dome	'C' Lever	D	E	Weight (kg)
	706	DN20	¾"	¾"	70	10	164	186	37	114	1.9	
		DN25	1"	1"	71	11	179	202	40	121	2.6	
		DN32	1¼"	1¼"	90	12.7	206	239	48	140	4.7	
		DN40	1½"	1½"	94	12.7	243	276	56	150	6.5	
		DN50	2"	2"	110	12.7	298	333	71	165	8.5	
716	DN20	¾"	1¼"	75	10	242	265	55	114	2.5		
	DN25	1"	1½"	75	11	261	284	60	121	3.2		
	DN32	1¼"	2"	95	12.7	332	365	70	140	5.7		
	DN40	1½"	2½"	105	12.7	379	418	81	150	9.0		
	DN50	2"	3"	120	12.7	422	464	96	165	12.5		

Flanged x Flanged		Valve Type	Valve Size	Inlet *NB	Outlet *NB	A	'C' Dome	'C' Lever	'C' Bellows	D	Weight (kg)
716 Iron	DN25	25	40	105	293	316	—	100	6.6		
	DN32	32	50	115	353	386	—	110	10.4		
	DN40	40	65	140	415	454	—	115	15.6		
	DN50	50	80	150	454	496	—	120	21.4		
	746	DN25	25	40	105	410	410	445	100	8.5	
DN32		32	50	115	455	455	490	110	14.0		
DN40		40	65	140	570	570	605	115	20.0		
DN50		50	80	150	615	615	665	120	30.0		
DN65		65	100	170	725	725	785	140	42.5		
DN80		80	125	195	825/925H	825/925H	865/965H	160	64.5		
DN100		100	150	220	925/1030H	925/1030H	955/1060	180	86.0		
756		DN25	25	40	105	—	410	—	100	8.5	
		DN32	32	50	115	—	455	—	110	14.0	
		DN40	40	65	140	—	570	—	115	20.0	
	DN50	50	80	150	—	615	—	120	30.0		
	DN65	65	100	170	—	725	—	140	42.5		
	DN80	80	125	195	—	825†	—	160	64.5		

Flange sizes listed are for:
 Cast Iron Flanges PN16x6
 Cast Steel Flanges PN 40x16
 Others available on request.

Valve Type	Valve Size	Inlet *NB	Outlet *NB	A	B CI	B CS	C CI	C CS	D	E	F (BSP) DRAIN	Weight (kg)
766	DN40	63.5	76	197	20	22	389	452	156	185	¾"	25
	DN50	76	102	229	22	24	498	498	181	200	½"	38
	DN65	89	127	279	24	24	570	660	219	235	½"	58
	DN80	102	152	295	24	24	670	702	238	235	½"	83

*NB = Nominal Bore.

† Add 100mm to the DN80 Fig.756 valve only for set pressures above 14 Barg.

Flanged x Flanged	

Flange sizes listed are for:
 Cast Iron Flanges PN16x6
 Cast Steel Flanges PN 40x16
 Others available on request.

AIR CAPACITY CHART (l/s) @ 0.3 BARG OR 10% OVERPRESSURE* AND 15°C

Set Pressure (Barg)	Valve Type 706 (BS6759 Pt2)						Valve Type 716 (BS6759 Pt2)					
	DN15	DN20	DN25	DN32	DN40	DN50	DN15	DN20	DN25	DN32	DN40	DN50
0.35	5.03	14.5	19.2	31.5	49.5	77.5	18.3	52.6	69.6	111	180	279
1.0	8.97	25.9	34.2	56.3	88.3	138	31.2	89.9	119	189	308	476
2.0	13.9	40.0	52.9	87.0	136	214	48.8	140	186	295	481	744
3.0	18.1	52.4	69.2	114	178	280	63.5	183	242	384	626	968
4.0	22.8	65.8	86.9	143	224	351	79.7	230	303	482	786	1215
5.0	27.3	79.1	105	172	270	422	95.9	276	365	580	945	1462
6.0	32.0	92.5	122	201	315	493	112	323	427	678	1105	1708
7.0	36.6	106	140	230	361	565	128	369	488	776	1265	1955
8.0	41.3	119	158	259	406	636	144	416	550	874	1424	2202
9.0	45.9	133	175	288	452	708	161	463	611	972	1584	2449
10.0	50.5	146	193	317	497	779	177	509	673	1070	1744	2696
12.0	59.8	173	228	375	588	921	209	603	796	1267	2063	3189
12.5	62.1	179	237	390	611	957	217	626	827	1316	2143	3313
14.0							242	696	920	1463	2382	3683
16.0							274	789	1043	1659	2701	4177
18.0							306	882	1166	1855	3021	4670
20.0							339	976	1289			
22.0							371	1069				
24.0							403	1162				
26.0							436					
28.0							468					
30.0							501					
32.0							533					
34.0												
36.0												
38.0												
40.0												

* Minimum overpressure = 0.07 Barg at set pressure less than 1.0 Barg.

Useful Conversions

Nm³/h = 1/sec x 3.60
SCFM = 1/sec x 2.12

Other Gases

If you wish to use the valve on other compatible gases, the sizing details above can be used. The valve capacity will however change depending on the specific gravity of the flowing gas. Multiply the valve air capacity by $1/\sqrt{SG}$ to give the gas capacity. SG = specific gravity (relative to air = 1).

AIR CAPACITY CHART (l/s) @ 0.3 BARG OR 10% OVERPRESSURE* AND 15°C

Set Pressure (Barg)	Valve Type 746 # (BS6759 Pt2)							Valve Type 776 (AD MERKBLATT A2)							
	DN25	DN32	DN40	DN50	DN65	DN80	DN100	1/2R DN20	1/2M DN15	1/2M1 DN20	1/3 DN20	1/4 DN25	1/5 DN32	1/6 DN40	1/7 DN50
0.35	69.6	109	178	275	467	711	1098	†	§	†	**				
1.0	115	182	297	459	781	1188	1836	14	26.9	26.9	71.3	77.5	103	163	265
2.0	181	287	468	723	1231	1872	2894	21	40.3	40.3	107	116	153	244	397
3.0	242	384	626	968	1646	2505	3872	30.5	58.7	58.7	155	169	224	356	579
4.0	303	482	786	1215	2066	3144	4859	38.2	73.4	73.4	205	211	279	444	723
5.0	365	580	945	1462	2486	3782	5846	45.8	88.0	88.0	246	253	335	533	868
6.0	427	678	1105	1708	2906	4421	6834	54	103	103	287	296	391	621	1012
7.0	488	776	1265	1955	3326	5060	7821	61	117	117	328	338	446	710	1156
8.0	550	874	1424	2202	3746	5699	8808	69	132	132	369	380	502	798	1301
9.0	611	972	1584	2449	4165	6337	9795	76	147	147	410	422	558	887	1445
10.0	673	1070	1744	2696	4585	6976	10783	84	161	161	451	464	613	976	1589
12.0	796	1267	2063	3189	5425	8253	12757	99	190	190	533	548	725	1153	1878
12.5	827	1316	2143	3313	5635	8573	13251	103	198	198	553	570	752	1197	1950
14.0	920	1463	2382	3683	6265	9531	14732	115	220	220	614	633	836	1330	2166
16.0	1043	1659	2701	4177	7104	10808	16706	129	249	249	696	717	948	1507	2455
18.0	1166	1855	3021	4670	7944	12086	18681	145	278	278	778	801	1059	1684	2743
20.0	1289	2051	3340	5164	8784	13363	20655	160	307	307	860	886	1171	1862	3032
22.0	1413	2247	3659	5658	9623	14641	22630	175	337	337	942	970			
24.0	1536	2443	3979	6151	10463	15918	24605	190	366	366	1024	1054			
26.0	1659	2639	4298	6645	11303	17196		205	395	395	1106	1139			
28.0	1782	2835	4617	7138	12142	18473		220	424	424	1187	1223			
30.0	1906	3031	4936	7632	12982	19751		236	454	454	1269	1307			
32.0	2029	3227	5256	8126	13822	21028									
34.0	2152	3423	5575	8619	14661										
36.0	2276	3619	5894	9113											
38.0	2399	3815	6214	9607											
40.0	2522	4011	6533	10100											

* Minimum overpressure = 0.07 Barg at set pressure less than 1.0 Barg.

The 746 can be sized/certified to ASME VIII and AD Merkblatt A2 - contact factory for details.

†DN20 x DN25
§DN15 x (DN20 or DN25)
†(DN20 or DN25 x DN25)
**DN20 x DN32

STEAM CAPACITY CHART (kg/h)

Set Pressure (Barg)	Saturated Steam Temp. °C	Valve Type 706 (BS6759 Pt1 @ 10% Overpressure)*						Valve Type 716 (BS6759 Pt1 @ 5% Overpressure)†					
		DN15	DN20	DN25	DN32	DN40	DN50	DN15	DN20	DN25	DN32	DN40	DN50
0.35	108	11.1	32.0	42.3	69.5	109	171	35.6	103	136	216	351	543
1.0	120	22.3	64.4	85.1	140	219	344	70.5	203	269	427	696	1075
2.0	134	36.6	106	140	230	360	564	125	359	475	755	1230	1902
3.0	144	49.4	143	188	310	486	761	167	480	635	1010	1645	2543
4.0	152	62.0	179	237	389	610	955	209	602	795	1265	2060	3185
5.0	159	74.5	215	285	468	734	1150	251	723	955	1519	2475	3826
6.0	165	87.1	252	333	547	857	1344	293	844	1115	1774	2889	4467
7.0	170	99.7	288	381	626	981	1538	335	965	1276	2029	3304	5108
8.0	175	112	324	429	705	1105	1732	377	1086	1436	2283	3719	5750
9.0	180	125	361	477	784	1229	1926	419	1207	1596	2538	4134	6391
10.0	184	138	397	525	863	1353	2120	461	1329	1756	2793	4549	7032
12.0	192	163	470	621	1021	1601	2508	545	1571	2076	3302	5378	8315
12.5	193	169	488	645	1061	1663	2605	566	1632	2156	3429	5586	8636
14.0	198							629	1831	2397	3811	6208	9598
16.0	204							714	2056	2717	4321	7038	10880
18.0	210							798	2298	3037	4830	7867	12163
20.0	215							882	2540	3357			
22.0	220							966	2783				
24.0	224												
26.0	228												
28.0	232												
30.0	236												
32.0	239												
34.0	243												
36.0	246												
38.0	249												
40.0	252												

* Minimum overpressure = 0.07 Barg at set pressure less than 0.7 Barg.
 † Minimum overpressure = 0.07 Barg at set pressure less than 1.0 Barg.

Useful Conversions
 lbs/h = kg/h x 2.2046

Other Temperatures
 The above tables are based on saturated steam, at the temperatures shown.
 For steam systems operating at higher temperatures, the above capacities will need to be derated by using the super heat correction factor.
 If you do not already have these figures, please consult the Bailey sales office.

STEAM CAPACITY CHART (kg/h)

Set Pressure (Barg)	Valve Type 746 # (BS6759 Pt1 @ 5% Overpressure)†							Valve Type 756 (BS6759 Pt1 @ 5% Overpressure)†						Metal Seat Valve Type 766 (BS6759 Pt1 @ 10% Overpressure)*			
	DN25	DN32	DN40	DN50	DN65	DN80	DN100	DN25	DN32	DN40	DN50	DN65	DN80	DN40	DN50	DN65	DN80
0.35	124	198	322	498	847	1289	1992	161	257	419	648	1101	1676	402	716	1119	1611
1.0	269	429	698	1079	1836	2793	4317	297	472	769	1189	2022	3076	893	1587	2480	3571
2.0	457	727	1183	1830	3112	4735	7318	486	773	1258	1945	3309	5034	1485	2640	4125	5940
3.0	635	1010	1645	2543	4326	6581	10173	650	1033	1683	2601	4425	6732	2065	3673	5738	8262
4.0	795	1265	2060	3185	5417	8241	12738	813	1294	2107	3257	5541	8429	2592	4609	7201	10369
5.0	955	1519	2475	3826	6508	9901	15303	977	1554	2531	3913	6656	10127	3119	5545	8664	12475
6.0	1115	1774	2889	4467	7598	11560	17869	1141	1815	2955	4567	7772	11825	3645	6482	10127	14582
7.0	1276	2029	3304	5108	8689	13220	20433	1305	2075	3380	5225	8888	13522	4172	7418	11591	16689
8.0	1436	2283	3719	5750	9780	14880	22999	1469	2336	3804	5881	10004	15220	4699	8355	13054	18795
9.0	1596	2538	4134	6391	10871	16539	25565	1632	2596	4228	6537	11120	16917	5226	9291	14517	20902
10.0	1756	2793	4549	7032	11962	18199	28130	1796	2857	4653	7193	12235	18615	5752	10228	15980	23009
12.0	2076	3302	5378	8315	14143	21518	33260	2124	3378	5501	8505	14467	22010	6806	12100	18906	27222
12.5	2156	3429	5586	8636	14689	22348	34543	2206	3508	5713	8833	15024	22859	7069	12569	19638	28276
14.0	2397	3811	6208	9598	16325	24838	38391	2451	3898	6350	9817	16699	25405	7859	13974	21832	31436
16.0	2717	4321	7038	10880	18587	28157	43522	2779	4419	7198	11129	18930	28800	8912	15847	24759	35649
18.0	3037	4830	7867	12163	20689	31476	48652	3107	4940	8047	12441	21162	32196	9965	17720	27685	39863
20.0	3357	5339	8697	13446	22871	34795	53783	3434	5461	8896	13753	23393	35591	11019	19593	30612	44076
22.0	3678	5849	9526	14728	25052	38115	58913	3762	5982	9744	15065	25625	38986	12072	21466	33538	48289
24.0	3998	6358	10356	16011	27234	41434	64044	4089	6503	10593	16377	27857	42381	13126	23338	36464	52503
26.0	4318	6868	11186	17293	29416	44753											
28.0	4638	7377	12015	18576	31598	48073											
30.0	4959	7886	12845	19859	33779	51392											
32.0	5279	8396	13675	21142	35961	54711											

* Minimum overpressure = 0.07 Barg at set pressure less than 0.7 Barg.
 † Minimum overpressure = 0.07 Barg at set pressure less than 1.0 Barg.
 # The 746 can be sized/certified to ASME VIII and AD Merkblatt A2 - contact factory for details.

WATER CAPACITY CHART (l/min) @ 10% OVERPRESSURE* @ 20°C

Set Pressure (Barg)	Valve Type 706 (BS6759 Pt3)						Valve Type 716 (BS6759 Pt3)					
	DN15	DN20	DN25	DN32	DN40	DN50	DN15	DN20	DN25	DN32	DN40	DN50
0.35	10.3	29.8	39.4	64.8	102	159	27.6	79.4	105	167	272	420
1.0	16.7	48.3	63.8	105	164	258	44.6	129	170	270	440	680
2.0	23.6	68.3	90.2	148	233	364	63.1	182	240	382	622	962
3.0	28.9	83.6	111	182	286	446	77.3	223	294	468	762	1178
4.0	33.4	96.5	128	210	329	515	89.3	257	340	540	880	1361
5.0	37.4	108	143	235	368	576	99.8	287	380	604	984	1521
6.0	40.9	118	156	257	403	631	109	315	416	662	1078	1667
7.0	44.2	128	169	278	435	682	118	340	449	715	1164	1800
8.0	47.3	137	180	297	465	729	126	364	481	764	1245	1924
9.0	50.1	145	191	315	493	773	134	386	510	811	1320	2041
10.0	52.8	153	202	332	520	815	141	406	537	854	1392	2152
12.0	57.9	167	221	363	570	893	155	445	589	936	1525	2357
12.5	59.1	171	226	371	581	911	158	454	601	955	1556	2406
14.0							167	481	636	1011	1647	2546
16.0							179	514	680	1081	1760	2722
18.0							189	545	721	1146	1867	2887
20.0							200	575	760			
22.0							209	603				
24.0							219	639				
26.0							227					
28.0							236					
30.0							244					
32.0							252					
34.0												
36.0												
38.0												
40.0												

* Minimum overpressure = 0.07 Barg at set pressure less than 0.7 Barg.

Useful Conversions
 l/gpm = 1/min x 0.22
 m³/min = 1/min x 0.001

Other Liquids
 If you wish to use the valve on other compatible liquids, the sizing details above can be used. The valve capacity will however change depending on the specific gravity of the flowing liquid. Multiply the valve water capacity by $1/\sqrt{SG}$ to give the liquid capacity.
 SG = specific gravity (relative to water = 1).

Maximum pressure per size based on 716 bronze valve. For 716 C1 and SS valves refer to page 23.

WATER CAPACITY CHART (l/min) @ 10% OVERPRESSURE* @ 20°C

Set Pressure (Barg)	Valve Type 746 # (BS6759 Pt3)						
	DN25	DN32	DN40	DN50	DN65	DN80	DN100
0.35	105	167	272	420	715	1088	
1.0	170	270	440	680	1157	1761	2722
2.0	240	382	622	962	1637	2490	3849
3.0	294	468	762	1178	2005	3050	4714
4.0	340	540	880	1361	2315	3522	5443
5.0	380	604	984	1521	2588	3937	6086
6.0	416	662	1078	1667	2835	4313	6666
7.0	449	715	1164	1800	3062	4659	7210
8.0	481	764	1245	1924	3273	4980	7698
9.0	510	811	1320	2041	3472	5282	8165
10.0	537	854	1392	2152	3660	5568	8606
12.0	589	936	1525	2357	4009	6099	9428
12.5	601	955	1556	2406	4092	6225	9622
14.0	636	1011	1647	2546	4330	6588	10183
16.0	680	1081	1760	2722	4629	7043	10886
18.0	721	1146	1867	2887	4910	7470	11547
20.0	760	1208	1968	3043	5176	7874	12171
22.0	797	1267	2064	3191	5428	8259	12765
24.0	832	1324	2156	3333	5670	8626	13332
26.0	866	1378	2244	3469	5901	8978	
28.0	899	1430	2329	3600	6124	9317	
30.0	931	1480	2410	3727	6339	9644	
32.0	961	1528	2490	3849	6547	9960	
34.0	991	1575	2566	3967	6748		
36.0	1019	1621	2641	4082			
38.0	1047	1666	2713	4194			
40.0	1074	1709	2783	4303			

* Minimum overpressure = 0.07 Barg at set pressure less than 0.7 Barg.

The 746 can be sized/certified to ASME VIII and AD Merkblatt A2 - contact factory for details.

HOT WATER CAPACITY CHART (kW) FOR A PRESSURISED (un-vented) SYSTEM

Set Pressure (Barg)	Valve Type 706 (BS6759 Pt1 @ 10% Overpressure)*						Valve Type 716 (BS6759 Pt1 @ 5% Overpressure)†					
	DN15	DN20	DN25	DN32	DN40	DN50	DN15	DN20	DN25	DN32	DN40	DN50
0.35	14.3	41.4	54.7	89.9	141	221	54.5	157	208	330	538	832
1.0	16.4	47.5	62.8	103	162	254	61.9	178	236	374	611	944
2.0	23.1	66.9	88.4	145	228	357	78.2	225	298	473	771	1192
3.0	30.9	89.4	118	194	304	477	105	301	398	633	1031	1594
4.0	38.8	112	148	244	382	599	131	377	498	792	1291	1996
5.0	46.7	135	178	293	460	720	157	453	599	952	1551	2398
6.0	54.6	158	208	343	537	842	184	529	699	1112	1811	2799
7.0	62.5	181	239	392	615	964	210	605	799	1271	2071	3201
8.0	70.5	203	269	442	693	1085	236	681	900	1431	2331	3603
9.0	78.3	226	299	491	770	1207	263	757	1000	1590	2591	4005
10.0	86.2	249	329	541	848	1329	289	833	1100	1750	2851	4407
12.0	102	294	389	640	1003	1572	342	984	1301	2069	3370	5211
12.5	106	306	404	665	1042	1633	355	1022	1351	2149	3500	5412
14.0							394	1136	1501	2388	3890	6015
16.0							447	1288	1703	2708	4410	6818
18.0							500	1440	1903	3027	4930	7622
20.0							553	1592	2104			
22.0							605	1744				
24.0												
26.0												
28.0												
30.0												
32.0												
34.0												
36.0												
38.0												
40.0												

* Minimum overpressure = 0.07 Barg at set pressure less than 0.7 Barg.
 † Minimum overpressure = 0.07 Barg at set pressure less than 1.0 Barg.

NOTE:
Pressurised (un-vented) hot water systems have the entire discharge capacity handled solely by the valve.
Open vented systems take into account the discharge capacities of the vent. Hence the equivalent discharge of the valve is considered to be double the above chart capacities.

HOT WATER CAPACITY CHART (kW) FOR A PRESSURISED (un-vented) SYSTEM

Set Pressure (Barg)	Valve Type 746 (BS6759 Pt1 @ 5% Overpressure)†							Resilient Seat Valve Type 766 (BS759 @ 10% Overpressure)*			
	DN25	DN32	DN40	DN50	DN65	DN80	DN100	DN40	DN50	DN65	DN80
0.35	227	360	587	907	1543	2547	3628	65	109	173	259
1.0	235	374	608	941	1600	2434	3762	180	316	500	720
2.0	309	492	801	1239	2107	3206	4956	362	646	1010	1440
3.0	398	633	1031	1594	2711	4124	6375	534	970	1490	2150
4.0	498	792	1291	1996	3394	5164	7983	710	1280	1990	2870
5.0	599	952	1551	2398	4078	6204	9590	900	1594	2490	3580
6.0	699	1112	1811	2799	4762	7244	11198	1080	1910	2990	4300
7.0	799	1271	2071	3201	5445	8285	12805	1260	2256	3500	5050
8.0	900	1431	2331	3603	6129	9721	14413	1442	2574	4010	5780
9.0	1000	1590	2591	4005	6813	10365	16020	1622	2900	4514	6500
10.0	1100	1750	2851	4407	7496	11405	17628	1806	3212	5020	7210
12.0	1301	2069	3370	5211	8863	13485	20843	2170	3860	6020	8630
12.5	1351	2149	3500	5412	9205	14005	21647	2258	4020	6265	8992
14.0	1501	2388	3890	6015	10231	15565	24058	2522	4500	7000	10080
16.0	1703	2708	4410	6818	11598	17645	27274	2882	5124	8016	11530
18.0	1903	3027	4930	7622	12965	19725	30489	3244	5770	9014	12980
20.0	2104	3346	5450	8426	14332	21805	33704	3602	6406	10000	14420
22.0	2304	3665	5970	9230	15699	23885	36919	3962	7036	11014	15840
24.0	2505	3984	6490	10034	17067	25965	40134	4326	7684	12000	17290
26.0	2706	4304	7010	10837	18434	28045					
28.0	2907	4623	7530	11641	19801	30125					
30.0	3107	4942	8050	12445	21168	32206					
32.0	3308	5261	8569	13249	22536	34286					
34.0	3509	5580	9089	14053	23903						
36.0	3710	5900	9609	14856							
38.0	3910	6219	10129	15660							
40.0	4111	6538	10649	16464							

* Minimum overpressure = 0.07 Barg at set pressure less than 0.7 Barg.
 † Minimum overpressure = 0.07 Barg at set pressure less than 1.0 Barg.

706 SPRING SELECTION CHARTS

DN15 Spring Range				DN32 Spring Range			
Part No	Barg	Psig	Colour code	Part No	Barg	Psig	Colour code
C2193	0.35 – 1.0	5 – 15	Red	C2220	0.35 – 1.0	5 – 15	Red
C2194	1.0 – 1.7	15 – 25	Blue	C0174	1.0 – 1.7	15 – 25	Blue
C2195	1.7 – 2.4	25 – 35	Orange	C2213	1.7 – 2.4	25 – 35	Orange
C2196	2.4 – 3.5	35 – 50	Orange/Blue	C2221	2.4 – 4.1	35 – 60	Orange/Blue
C2197	3.5 – 5.5	50 – 80	Green/White	C2214	4.1 – 5.5	60 – 80	Purple
C2198	5.5 – 8.3	80 – 120	Green/Blue	C2222	5.5 – 8.3	80 – 120	Green/White
C2199	8.3 – 12.5	120 – 180	White/Blue	C2215	8.3 – 10.3	120 – 150	Green/Blue
				C2223	10.3 – 12.5	150 – 180	White/Blue

DN20 Spring Range				DN40 Spring Range			
Part No	Barg	Psig	Colour code	Part No	Barg	Psig	Colour code
C2187	0.35 – 1.0	5 – 15	Red	C2224	0.35 – 1.0	5 – 15	Red
C2188	1.0 – 1.7	15 – 25	Blue	C2216	1.0 – 1.7	15 – 25	Blue
C2189	1.7 – 3.5	25 – 50	Orange	C0709	1.7 – 2.4	25 – 35	Orange
C2190	3.5 – 6.9	50 – 100	Orange/Blue	C2225	2.4 – 4.1	35 – 60	Orange/Blue
C2191	6.9 – 10.3	100 – 150	Purple	C2226	4.1 – 5.5	60 – 80	Purple
C2192*	10.3 – 12.5	150 – 180	Green/White	C2217	5.5 – 8.3	80 – 120	Green/White
C2200†	10.3 – 12.5	150 – 180	White/Blue	C2208	8.3 – 10.3	120 – 150	Green/Blue
				C2218	10.3 – 12.5	150 – 180	White/Blue

DN25 Spring Range				DN50 Spring Range			
Part No	Barg	Psig	Colour code	Part No	Barg	Psig	Colour code
C0139	0.35 – 1.0	5 – 15	Red	C2227	0.35 – 1.0	5 – 15	Red
C0145	1.0 – 1.7	15 – 25	Blue	C0718	1.0 – 1.7	15 – 25	Blue
C0147	1.7 – 2.4	25 – 35	Orange	C0719	1.7 – 2.4	25 – 35	Orange
C2182	2.4 – 4.1	35 – 60	Orange/Blue	C2219	2.4 – 4.1	35 – 60	Orange/Blue
				C2228	4.1 – 5.5	60 – 80	Purple
				C2229	5.5 – 8.3	80 – 120	Green/White
				C2209	8.3 – 10.3	120 – 150	Green/Blue
				C2230	10.3 – 12.5	150 – 180	White/Blue

Air and Pumped Liquids only			
Part No	Barg	Psig	Colour code
C2183	4.1 – 5.5	60 – 80	Purple
C2184	5.5 – 8.3	80 – 120	Green/White
C2185	8.3 – 10.3	120 – 150	Green/Blue
C2186	10.3 – 12.5	150 – 180	White/Blue

Steam and Hot Water only			
Part No	Barg	Psig	Colour code
C2183	4.1 – 6.9	60 – 100	Purple
C2184	6.9 – 10.3	100 – 150	Green/White
C2185	10.3 – 12.5	150 – 180	Green/Blue

Springs listed above comply with the requirements of BS6759:Part 1.

716 SPRING SELECTION CHARTS

DN15 Spring Range				DN32 Spring Range			
Part No	Barg	Psig	Colour code	Part No	Barg	Psig	Colour code
C0074	0.35 – 1.0	5 – 15	Red	C0452	0.35 – 1.0	5 – 14	Red
C2133	1.0 – 1.7	15 – 25	Blue	C0457	1.0 – 1.7	14 – 25	Blue
C2134	1.7 – 2.4	25 – 35	Orange	C0461	1.7 – 3.1	25 – 45	Orange
C2135	2.4 – 4.1	35 – 60	Orange/Blue	C0467	3.1 – 4.1	45 – 60	Orange/Blue
C2136	4.1 – 6.9	60 – 100	Green/White	C0469	4.1 – 5.5	60 – 80	Purple
C2137	6.9 – 10.3	100 – 150	Green/Blue	C0472	5.5 – 8.6	80 – 125	Green/White
C2138	10.3 – 12.4	150 – 180	White/Blue	C0475	8.6 – 10.3	125 – 150	Green/Blue
C2181	12.4 – 15.5	180 – 225	—	C0476	10.3 – 12.8	150 – 185	White/Blue
C0623	15.5 – 18.6	225 – 270	White	C0477	11.4 – 13.8	166 – 200	—
C2169	18.6 – 22.1	270 – 320	—	C0478	12.6 – 15.2	183 – 220	—
C0645	22.1 – 26.5	320 – 384	Red/Yellow	C0479	13.9 – 16.8	202 – 243	—
C2201	26.5 – 27.6	384 – 400	—	C0480	15.4 – 18.5	223 – 268	—
C0651	27.6 – 32.0	400 – 464	Red/Green				

DN20 Spring Range				DN40 Spring Range			
Part No	Barg	Psig	Colour code	Part No	Barg	Psig	Colour code
C0686	0.35 – 1.0	5 – 14	Red	C0508	0.35 – 1.0	5 – 14	Red
C0688	1.0 – 2.1	14 – 30	Blue	C0492	1.0 – 1.7	14 – 25	Blue
C0689	2.1 – 2.8	30 – 40	Orange	C0495	1.7 – 3.1	25 – 45	Orange
C2125	2.8 – 3.8	40 – 55	Orange/Blue	C0498	3.1 – 4.1	45 – 60	Orange/Blue
C0690	3.8 – 5.5	55 – 80	Purple	C0499	4.1 – 5.5	60 – 80	Purple
C2126	5.5 – 7.6	80 – 110	Green/White	C0501	5.5 – 8.6	80 – 125	Green/White
C0691	7.6 – 10.3	110 – 150	Green/Blue	C0503	8.6 – 10.3	125 – 150	Green/Blue
C2127	10.3 – 12.4	150 – 180	White/Blue	C0504	10.3 – 12.8	150 – 185	White/Blue
C2178	12.4 – 15.5	180 – 225	—	C0505	11.4 – 13.8	166 – 200	—
C0693	15.5 – 18.6	225 – 270	White	C0506	12.6 – 15.2	183 – 220	—
C2170	18.6 – 20.3	270 – 295	—	C0507	15.4 – 18.5	223 – 268	—
C0694	20.3 – 24.5	295 – 355	Red/Yellow				

DN25 Spring Range				DN50 Spring Range			
Part No	Barg	Psig	Colour code	Part No	Barg	Psig	Colour code
C2119	0.35 – 1.0	5 – 14	Red	C0919	0.35 – 1.0	5 – 14	Red
C2120	1.0 – 1.7	14 – 25	Blue	C0922	1.0 – 1.7	14 – 25	Blue
C2121	1.7 – 3.1	25 – 45	Orange	C0924	1.7 – 3.1	25 – 45	Orange
C2114	3.1 – 4.1	45 – 60	Orange/Blue	C1400	3.1 – 4.1	45 – 60	Orange/Blue
C2113	4.1 – 5.5	60 – 80	Purple	C0928	4.1 – 5.5	60 – 80	Purple
C2122	5.5 – 8.6	80 – 125	Green/White	C0930	5.5 – 8.6	80 – 125	Green/White
C2123	8.6 – 10.7	125 – 155	Green/Blue	C0933	8.6 – 10.3	125 – 150	Green/Blue
C2124	10.7 – 12.8	155 – 185	White/Blue	C0934	10.3 – 12.8	150 – 185	White/Blue
C2202	12.8 – 13.2	185 – 192	—	C0935	11.4 – 13.8	166 – 200	—
C2234	13.2 – 15.4	192 – 223	—	C0936	12.8 – 15.4	185 – 223	—
C2203	15.4 – 17.6	223 – 255	—	C0937	14.5 – 17.4	210 – 253	—
C2235	17.6 – 20.5	255 – 297	—	C0939	15.4 – 18.5	223 – 268	—

- Springs up to 12.5 Barg (181 Psig) listed above for all materials comply with the requirements of BS6759:Part 1.
- The cast iron 716 is only available up to 13 Barg (188 Psig) on any medium.
- The stainless steel 716 is only available up to 12.5 Barg (181 Psig) on any medium.
- Stainless steel springs are available for 716 to the same pressures as shown above.
- Spring charts for 746/756/766/776 are available on request.

700 SERIES TECHNICAL SPECIFICATION

Fig. No	706	716	746	756	766	776
Body Material	Bronze	Bronze Cast Iron Stainless Steel	Cast Steel Stainless Steel	Cast Steel	Cast Iron Cast Steel	Bronze
Approvals Code Part	1, 2, & 3	1, 2, & 3	BS6759 1, 2, & 3#	1	1	AD MERKBLATT A2
Top Guided	Yes	Yes	Yes	Yes	Yes	Yes
Lift	High Lift	Full Lift	Full Lift	Full Lift	High Lift	Full Lift
Size Range	DN15-50 ½" - 2"	DN15-50 ½" - 2"	DN25-100 1" - 4"	DN25-80 1" - 3"	DN40-80 1½" - 3"	DN15-50 ½" - 2"
Orifice Areas (mm ²)						Sizing data to TUV available on request.
DN15	126	109	—	—	—	
DN20	364	314	—	—	—	
DN25	481	415	415	415	—	
DN32	791	660	660	660	—	
DN40	1240	1075	1075	1075	2280	
DN50	1943	1662	1662	1662	4054	
DN65	—	—	2827	2827	6334	
DN80	—	—	4301	4301	9121	
DN100	—	—	6648	—	—	
Pressure Range † (Barg)	0.35 to 12.5	0.35 to 32	0.35 to 40	0.35 to 24	0.35 to 24	1 to 41.3
Temp Range (°C) (with suitable material)	-59 to +220	-90 to +260	-40 to +427	-29 to +300	-29 to +230	-196 to +60
Connection	Screwed Flanged	Screwed Flanged	Flanged	Flanged	Flanged	Screwed
Trim Options	Brass EPDM (WRC) Viton	Stainless Aflas EPDM††	Stainless Aflas EPDM	Stainless EPDM	Stainless EPDM	KEL F (PCTFE)
Cap Options	Dome Open lever	Dome Open lever	Dome Open lever Packed lever	Open lever	Open lever	Dome
Kdr. Cert. Coeff. Steam/Hot Water/Gases	0.173	0.7	0.7	0.716	0.4	—
Kdr. Cert. Coeff. Liquids	0.149	0.46	0.46	—	—	—
Maximum Back Pressure	Brz 5.5 Barg	Brz 5.5 Barg CI 5.5 Barg SS 5.5 Barg	CS 16 Barg SS 16 Barg	CS 12 Barg	CI 6 Barg CS 12 Barg	Brz 5.5 Barg SS 5.5 Barg
Maximum Back Pressure*	Constant Built-up Variable	80% 10% —	80% 10% —	80% 10% 40%	— 50% —	80% 10% —

*For higher back pressures consult factory. **Resilient 766 is limited to 10%.
 †For maximum pressure per size and material refer to capacity and spring charts, pages 14 to 23.
 ††716 EPDM Seat, max pressure of 12.5 Barg on DN 15, 20, 25 and 18 Barg on DN 32, 40, 50.
 #746 is also available ASME VIII and AD Merkblatt A2 certified, details available on request.

Material Temperature Limitations	Seat	Body
	EPDM (WRC)	Bronze
	EPDM	Cast Iron
	Aflas	Carbon Steel
	Brass	Stainless Steel
	Stainless Steel	
	Viton	
	KEL F	
		-196°C to 220°C
		0°C to 220°C
		-29°C to 427°C
		-270°C to 427°C

Bailey
700 Series
 Safety Relief Valves



Specification

700 Series